

VEGATRONIC 6400

FLEXIBLE PACKAGING SOLUTIONS



MAIN FEATURES

- 1 • Ultra-sanitary continuous film motion machine
- 2 • Revolutionary open frame design
- 3 • Continuous film motion VFFS machine
- 4 • Hygienic open frame design

BENEFITS

- 1 • Wash down execution
- 2 • Unrestricted accessibility - Reduced maintenance down-time
- Easy monitoring for all machine components - Unrestricted accessibility - Easiness of use
- 3 • Top performance with lowest cost of ownership
- 4 • Limited harboring of bacteria, IP66 or higher grade components

Unrivalled HYGIENE and EASINESS of use are the hallmarks of this game-changing piece of kit. Vegatronic 6400 open frame is today's most innovative and high-tech VFFS machine.

It's a high-quality, high-end range machine with excellent sanitary design. Ideal to run a wide variety of products in harsh conditions.

TECHNICAL DATA

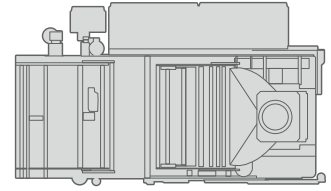
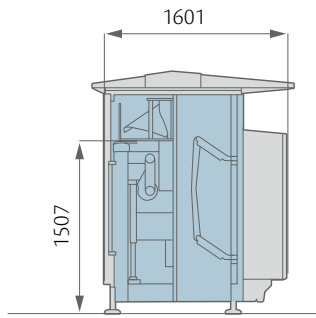
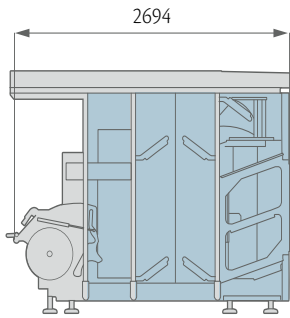

	S	P	SP
Machine Speed	120 cpm		
Wrapping Materials	Heat sealable materials, such as polypropylene, barrier films, laminates, polyethylene films, as well as paper based and recyclable films		
Sealing System (Horizontal and Vertical)*	Standard heat-seal jaws	Ilaseal or Ilatherm jaws	Both S & P system
Electronic Platform	Industrial PC, Allen Bradley (optional)		
Program Memory	200 programs		
HMI	12" colour touch screen (16:10 screen)		
Power Requirement	400 Vac +/-5%, 3 ph, neutral, GND, 50 Hz, 11 kW, 16 A		
Compressed Air	up to 125 l/min at 5 bar - 72,5 psi	up to 225 l/min at 5 bar - 72,5 psi	Same as per S or P
Machine Handling	Right hand version, left hand version (optional)		
Machine Dimensions	(Width x Depth x Height) 1600 x 2700 x 1500 - 63" x 106" x 59"		
Machine finish	Stainless steel		
Machine Weight	Approx. 1600 kg - 3525 lbs		
BAG SIZE	S	P	SP
length	500mm - 19.7"		
width min	75mm - 3"		
width max	370/380mm* - 14,5"/15"	360/370mm* - 14,2"/14,5"	Same as per S or P
FILM REEL DIMENSIONS	S	P	SP
Reel width max	830mm - 32,5"		
reel outer ø max	up to 500 mm - 19,7"		
reel core ø max	76mm - 3.0"		

* Rotating sealing band/Hot air system