

PH3000

FLEXIBLE PACKAGING SOLUTIONS

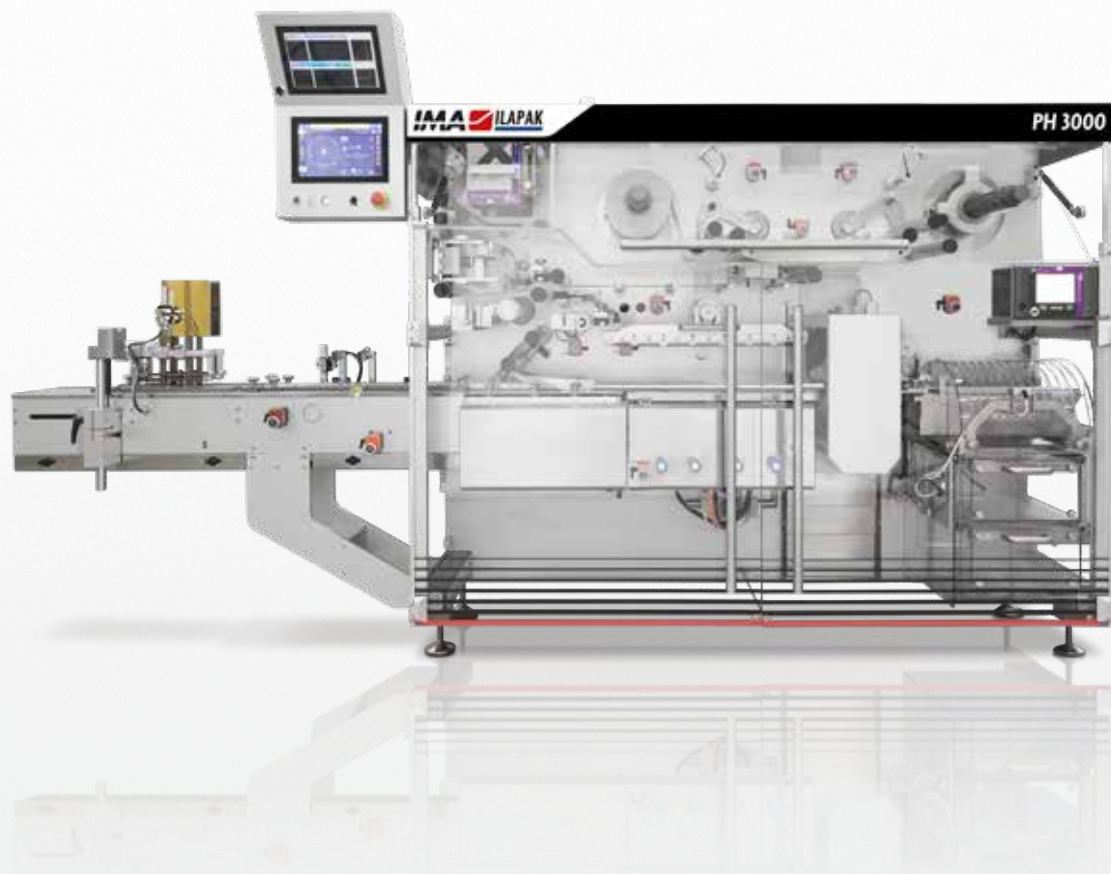

MAIN FEATURES

- 1 • Designed for Pharma and Medical hermetic wrapping applications
- 2 • Suitable either for integration into IMA lines or flow wrap stand-alone applications. By-pass featured
- 3 • Separated and swivel electrical control panel from the mechanical part
- 4 • High speed long dwell sealing jaws technology, single or multiple jaws option

The new PH 3000 is a flow wrapping platform conceived for Pharma & Medical applications offering superior performances in speed and sealing tightness. Hygienic and balcony style design allow film and product path always visible and accessible. The machine is featured with in-line by pass, containment & clean-room compliance. Ilapak's PH 3000 also offers a wide solutions of features such as printing OCR/OCV, automatic feeding and 21 CFR Part 11

BENEFITS

- 1 • Minimised footprint & in-line length. New architecture
- 2 • Many automatic feeding solutions available. Modular/configurable HD platform. Superior tech & performances content
- 3 • Easy accessibility during maintenance operation
- 4 • To perform hermetic sealing, map application, managing a wide range of wrapping material characteristics

TECHNICAL DATA

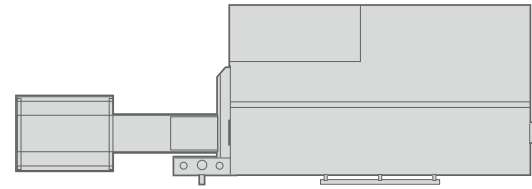
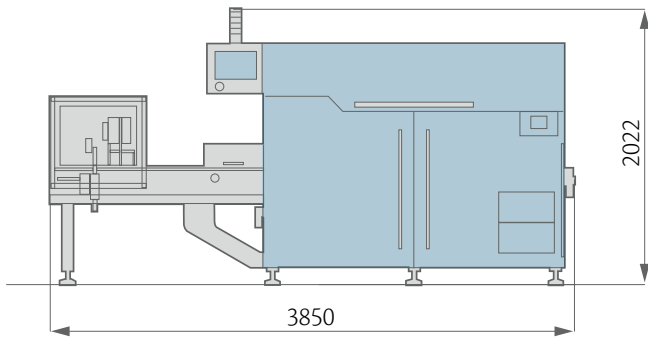

Machine Speed	Up to 450 cycles per minute Production output depends on film sealability and product characteristics
Film Cut-Off	Min 60mm - 2.4" / Max 400mm - 16" Depending on film and product characteristics
Wrapping Materials	Alu based material, laminated, co-extruded and all sealable films
Film Reel Max Weight	Depending on film reel width, up to 50 kg - 110 lbs
Electronic Platform	Industrial PC
Power Requirement	From 220 to 480 V, 50/60 Hz, 7kVA
Compressed Air	6 bar, 200l/min
Machine Weight	1400 Kg - 3100 lbs
	PRODUCT DIMENSIONS
length	Up to 250mm - 10" standard
width	Up to 100mm - 4" standard
height	Up to 100mm - 4" standard
	FILM REEL DIMENSIONS
coreø	76.2mm - 3" standard
outerø	400mm - 12"
width	300mm - 19.7" standard